

# **Brinsea**

## Mini Eco high performance egg incubator

### User instructions

#### Contents

<u>Section</u>	<u>Subject</u>	<u>Page</u>
1	Introduction	2
2	Unpacking	3
3	Location and Installation	3
4	Storage of eggs	4
5	Temperature	4
6	Humidity and Ventilation	5
7	Egg setting	5
8	Egg turning	6
9	Hatching	6
10	Cleaning up	6
11	Servicing	7
12	Troubleshooting	7
13	Specification	8

# 1 Introduction

These instructions detail the operation of your new Mini Eco digital incubator. Please read these instructions carefully before setting up your machine to achieve best results and keep these instructions safe for future reference. This document includes recommended procedures for successful hatching but incubation involves the control and manipulation of a large number of factors and in certain circumstances different procedures may be necessary. Your incubator is designed to allow the user to vary the incubation conditions to suit a wide range of species in different ambient conditions and the specific set-up for every situation is beyond the scope of these instructions.

There is a range of books available covering incubation techniques, for more information or to request a book list please don't hesitate to contact us.

Fig. 1 Functional features of the Mini Eco

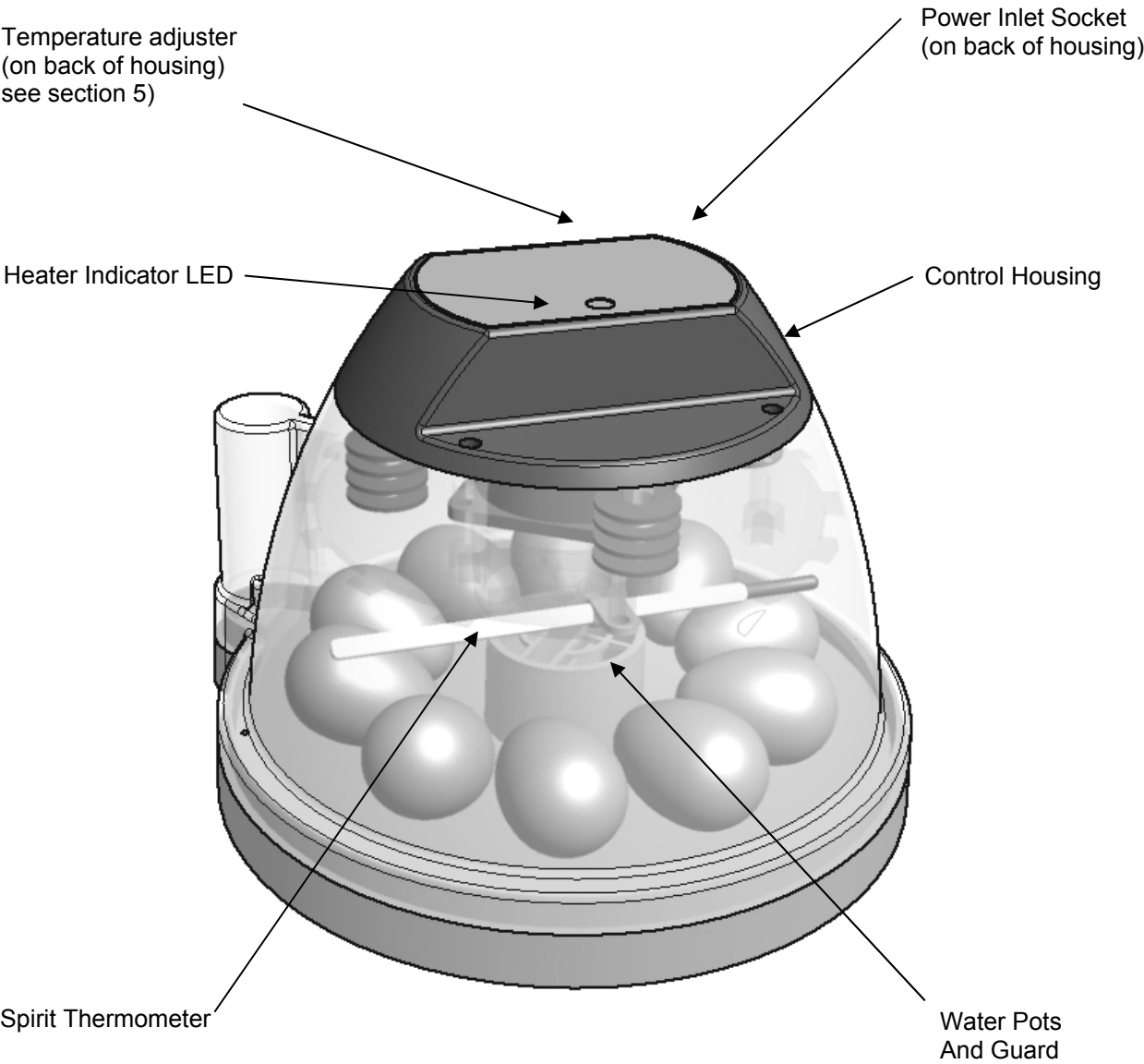

DO NOT COVER THE INCUBATOR. FOR INDOOR USE ONLY. THE INCUBATOR MUST BE PLACED IN AN AREA NOT SUBJECT TO SPLASHES OF WATER OR WET CONDITIONS AND OUT OF REACH OF ANIMALS AND CHILDREN.

THIS INCUBATOR IS NOT A TOY AND MAY ONLY BE OPERATED BY CHILDREN UNDER ADULT SUPERVISION.

FOR CONTINUED PROTECTION AGAINST FIRE AND ELECTRIC SHOCK ONLY USE THE POWER SUPPLY UNIT AS SUPPLIED WITH THE INCUBATOR. Spares are available from Brinsea Products Ltd.

## 2 Unpacking

Your incubator has been supplied in protective packaging. Please remove all tape, strapping and packing from the incubator and parts. Retain the carton and packing materials to enable the unit to be repacked.

Your incubator will include as standard:

Quantity	Item
1	Incubator (including removable lid)
1	Power Supply Unit
1	Water Pot Guard

- 2.1 Please identify each part and check that they are all present and undamaged. If there are any parts damaged or missing please contact your retailer or Brinsea Products (at the address at the end of the document).
- 2.2 To register your new Brinsea product please visit [www.brinsea.co.uk](http://www.brinsea.co.uk) and follow the link on the right hand side of the home page to qualify for your free 2 year guarantee.
- 2.3 Go to [www.Brinsea.co.uk](http://www.Brinsea.co.uk) and register as a free member of the Brinsea Email Group to receive the latest news and information such as advance notice about new products, special offers, exclusive competitions and much more.

## 3 Location and Installation

- 3.1 Your incubator will give best results in a room free from wide temperature variations and with generous ventilation – particularly if several incubators are running at the same time. Ensure that the room temperature cannot drop on a cold night. Ideally thermostatically control the room at between 20 and 25°C (68 and 77°F). **Never allow the room temperature to drop below 17°C (63°F) and ensure that the incubator cannot be exposed to direct sunlight.**
- 3.2 **ONLY USE THE POWER SUPPLY UNIT SUPPLIED WITH THE PRODUCT. USE OF A DIFFERENT POWER SUPPLY MAY CAUSE A HAZARD AND WILL INVALIDATE ANY WARANTEE.**
- 3.3 Connect the power supply unit cable to the socket on the back of the incubator lid. Ensure the connector is pushed fully home in its socket.
- 3.4 Place the incubator on a flat, level surface that is resistant to moisture and scratches. The base of the incubator must sit flat on the surface as this traps air under it as part of the thermal insulation.
- 3.5 Remove the lid and fill one of the two water pots with water or 100:1 Brinsea Incubation Disinfectant Solution. **Fit the water pot guard to prevent chicks drowning.**

- 3.6 Plug the power supply unit into a suitable outlet ensuring that the cable is not pulled tight. The incubator fan will start and the red heater indicator LED will light continuously.
- 3.7 Allow the incubator to run for at least an hour to stabilise the temperature before making adjustments or setting eggs.

## 4 Storage of Eggs

- 4.1 Store eggs in cool, damp conditions. Most species may be safely stored for up to 14 days before serious reductions in hatch rates are likely. Daily turning of stored eggs also helps maintain hatchability.
- 4.2 Discard cracked, mis-shaped and heavily soiled eggs (if possible). Only wash soiled eggs using a brand egg wash solution such as Brinsea Incubation Disinfectant Concentrate following the manufacturer's instructions. It is essential to wash eggs in solution which is significantly warmer than the egg. Bear in mind that all solutions will remove the outer cuticle from the egg as well as the dirt and may leave the egg at greater risk from bacterial contamination in the future.

## 5 Temperature

*Stable and correct temperature is essential for good results. Adjust with care.*

- 5.1 **Your incubator has been factory set to the correct temperature for most species (37.4 – 37.6) but it is advisable to check the temperature and follow this procedure:-**
- 5.2 As the incubator warms up and approaches its control setting the red LED will change from continuously on to flashing. Allow the incubator to stabilise for at least an hour before adjusting the temperature.
- 5.3 If the temperature needs to be adjusted use a small, straight bladed screwdriver with a head no wider than 2mm (1/16<sup>th</sup> inch) to turn the adjuster screw inside the hole on the rear of the control housing. Gently insert the screwdriver and turn it until it engages in the adjuster screw slot. Do not force an inappropriate screwdriver into the housing, it may damage the adjustment unit and invalidate the warrantee.

Temperature adjuster  
screw inside hole

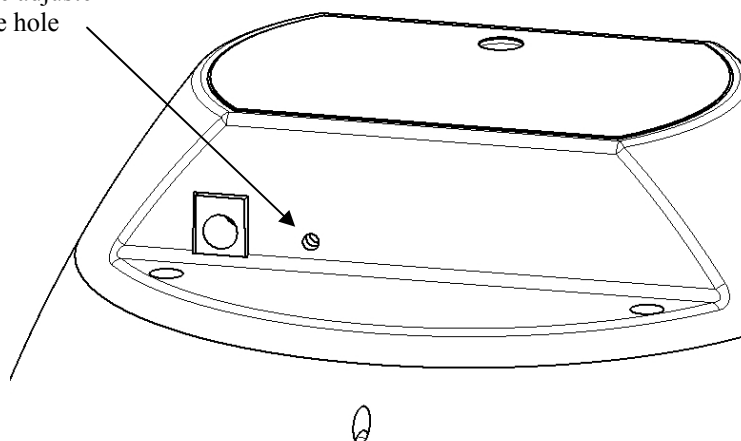

- 5.4 Turn clockwise to increase temperature, anticlockwise to reduce it. ¼ of a turn is approximately 2 degrees Celsius (4 Fahrenheit). Make very small adjustments and allow time for the temperature to stabilise between adjustments.
- 5.5 Refer to the thermometer to check temperature. Adjust temperature with care – small differences have large effects on hatching performance.

- |     |                           |                            |               |            |
|-----|---------------------------|----------------------------|---------------|------------|
| 5.6 | Recommended temperatures: | Typical incubation period: |               |            |
|     | Hens                      | 37.4 – 37.6°C              | 99.3 – 99.6°F | 21 days    |
|     | Pheasant                  | 37.6 – 37.8°C              | 99.6 - 100°F  | 23-27 days |
|     | Quail                     | 37.6 – 37.8°C              | 99.6 - 100°F  | 16-23 days |
|     | Ducks                     | 37.4 – 37.6°C              | 99.3 – 99.6°F | 28 days    |
- 5.7 Developing embryos are fairly tolerant of short term temperature drops and the user need not be concerned about cooling that occurs when inspecting eggs. Temperatures above ideal can quickly have a serious detrimental effect on hatch rates and must be avoided.

## 6 Humidity and Ventilation

*Correct humidity levels are important for successful incubation. Short term variations in humidity are not important. The average humidity over the incubation period needs to be near optimum to achieve the ideal weight loss. High humidity for the day or two of hatching is also important. Beware chronic, excessive humidity.*

*For more detailed information download the [Brinsea Incubation Handbook](http://www.brinsea.co.uk) free of charge at [www.brinsea.co.uk](http://www.brinsea.co.uk)*

- 6.1 As a general guide for poultry/game/waterfowl maintain water in one of the two water pots from the time eggs are set until 2 days before hatching is due - the depth of water doesn't matter. If the incubator is full of parrot (and parrot like species) eggs the incubator may be run without water for some of the early incubation period.

For all species ensure the water level is above the divider between the two pots for the last two days of incubation. Higher humidity levels are needed for hatching to prevent membranes drying too quickly. **Fit the water pot guard to prevent chicks drowning.**

The above guidelines make no provision for different ambient conditions and are necessarily rather generalised but they are simple and often effective.

- 6.2 In all cases the humidity for hatching needs to be high. Because of the short duration involved water/weight loss will not be significantly affected. High humidity is necessary to prevent membranes drying and hardening before the hatch fully emerges. Humidity will naturally increase as the first eggs begin to hatch and internal membranes begin to dry. This effect is in addition to the increased area of water evaporation from the water pots.
- 6.3 During hatching the high humidity levels will fall dramatically when the lid is opened and will take some time to build up. Resist the temptation to lift the lid frequently – leave for at least 6 hours between inspections.

## 7 Egg Setting

- 7.1 The Mini Eco is designed to accommodate eggs of different sizes up to duck eggs. Some experimentation may be necessary to maximise capacity. Before setting eggs ensure that the incubator has been run for several hours and has stabilised at the correct temperature.
- 7.2 Set the eggs at least 2cm in from the edge of the incubator base so that they are clear of the “skirt” of the lid when it is fitted.
- 7.3 Once the eggs have been set the temperature must not be adjusted for 24 hours to allow the eggs to warm. Check the water level every 3 days or so and temperature daily. Candle the eggs after 1/3rd of the incubation period has elapsed to reject clear, infertile eggs (see section 12).

## 8 Egg Turning

- 8.1 Mark each egg with a pencil “X” one side and “O” the other. This ensures that you can see which eggs you have turned. Turn three times a day starting on the second day.
- 8.2 Always turn about the pointed end to reduce the chance of damaging the internal structures of the egg.

## 9 Hatching

- 9.1 Stop turning the eggs 2 days before they are due to hatch.
- 9.2 For cleanliness it is recommended to place a sheet of kitchen paper or similar in the bottom of the incubator under the eggs when they are due to hatch. Tear a hole in the middle to fit over the water pots. This also helps the chicks stand more comfortably.
- 9.3 Hatching humidity levels need to be high (see section 6 above). Ensure the water pots are full to above the divider between them. **Fit the water pot guard to prevent chicks drowning.**
- 9.4 When most eggs have hatched (12 to 48 hours after the first egg hatches) remove the hatchlings to a brooder. The Brinsea Cosylamp is ideal for poultry and waterfowl etc.
- 9.5 During hatching the high humidity levels will fall dramatically when the lid is lifted and will take some time to build up. Resist the temptation to open the incubator frequently – leave for at least 6 hours between inspections.

## 10 Cleaning Up

IMPORTANT:

DISCONNECT THE INCUBATOR FROM THE MAINS POWER SUPPLY DURING CLEANING.

ENSURE THAT ALL ELECTRICAL PARTS ARE KEPT DRY. DO NOT IMMERSE THE INCUBATOR TOP.

- 10.1 NEVER WASH THE BASE, COVERS OR CABINET PARTS IN LIQUIDS OVER 50°C (120°F). DO NOT USE A DISHWASHER TO CLEAN TRAYS, INCUBATOR BASE OR LID. Following each hatch in the Mini Eco wash the base in Brinsea Incubation Disinfectant Solution. Wipe all other internal surfaces with a soft cloth soaked in the solution. Ensure that the instructions supplied with the fluid are followed.
- 10.2 Be sure to clean the air vent holes to keep them clear. There are two small holes on the bottom “skirt” of the lid and one on the back of the clear part of the lid above the level of the fan cover.
- 10.3 If a separate hatcher is used the procedure above should still be followed every two months.
- 10.4 Periodically unscrew the four screws retaining the fan cover, remove the cover and soak. Dust and fluff may be removed from the fan and heater cord with a soft brush. USE NO LIQUIDS. DO NOT TURN THE LID OVER AS THE FAN IS NOT FIXED ONCE THE FAN COVER IS REMOVED. The fan should be located on the 4 pegs under the lid before the cover is re-fitted.

**THE INCUBATOR MUST NOT BE USED WITHOUT THE FAN COVER FITTED. THE COVER SUPPORTS THE FAN AND PROVIDES PROTECTION FROM THE MOVING BLADES.**

- 10.5 The exterior of the incubator may be cleaned with a damp cloth. Avoid allowing any moisture to get inside electrical housings.
- 10.6 ALWAYS CLEAN THE INCUBATOR BEFORE STORAGE AND ENSURE THAT THE UNIT IS TOTALLY DRY INSIDE AND OUT. ALLOW IT TO RUN FOR 24 HOURS WITH NO WATER IN TO ENSURE IT IS THOROUGHLY DRY.

## 11 Servicing

- 11.1 In case of failure first check that the mains Power Supply Unit is fully engaged in the socket and that its lead and plug are fully engaged in the socket in the top of the incubator.

If the problem persists contact your distributor or Brinsea Products Service Dept.

- 11.2 The functional parts of the Mini Eco are modular and parts are available and are readily exchanged by a suitably qualified person equipped with basic tools. Fitting instructions are supplied with replacement parts.

## 12 Troubleshooting

- 12.1 Poor hatching results are frustrating and can be caused by a large number of factors. The most common are given below. Brinsea Products will not be held responsible for loss of eggs or chicks under any circumstances. However we will try to advise on incubation technique to improve results where necessary.
- 12.2 Gather as much information from the hatching results as possible to enable the problem to be analysed in detail. Record dates that eggs are set, incubator settings, dates of hatches, weight losses and the number and condition of hatchlings. Candle or break open unhatched eggs to estimate the extent of embryo development. The Brinsea Cool-Lume or Egg-Lume candling lamps are available from your dealer.

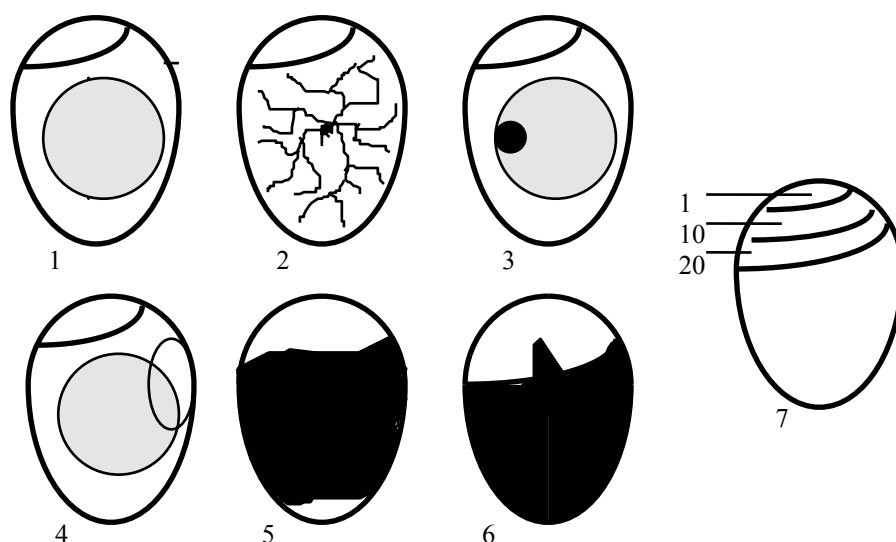

- 1) Clear when candled - probably infertile (or very early death) when candled at 8 days
- 2) Fertile with red blood vessels - after 8 days
- 3) Red or black staining - early death when candled at 8 days
- 4) Embryo with red blood 'ring' - early death when candled at 8 days
- 5) Dark outline with ill defined detail - late death (10-16 days)
- 6) Live embryo with bill in air sack - due to hatch in 24-48 hours
- 7) Normal development of the air pocket according to number of days

General guides:

<b>Observation</b>	<b>Likely Cause(s)</b>	<b>Solution(s)</b>
No chicks hatch	Infertility, infection, drastically incorrect incubation settings, parent ill health.	Check egg viability – are similar eggs hatching naturally. Disinfect the incubator. Check incubator settings and procedures – particularly temperature.
Chicks hatch earlier than expected, deformities.	Incubation temperature too high	Reduce incubation temperature slightly 0.5°C (1°F)
Chicks hatch later than expected	Incubation temperature too low	Raise incubation temperature slightly 0.5°C (1°F)
Hatch dates widely spread	Different rates of development due to different storage times, incubation temperature variation.	Limit egg storage times. Check for incubation temperature variation – sunlight, large room variation etc.
Late stage ‘death in shell’	Incorrect humidity, probably too high.	Try reducing average humidity levels (but see section 8 above)
Generally poor results	Incorrect incubation settings, poor parent bird health, inadequate egg turning,	Improve parent bird health, check all incubation settings, analyse egg weight loss to confirm humidity correct, check turning working correctly.

## 13 Specification

Mini Eco Maximum Setting Capacities:

Egg size	Typical capacity
Quail	24
Pheasant	12
Hen	10
Duck	8
Dimensions:	22cm x 22cm x 16.5cm high
Weight:	0.65 Kg
Power Consumption:	
Incubator maximum	18 Watts
(typical average)	12 Watts
Power Supply Unit:	100 - 230v, 50Hz, 0.5A max.

**Registered Community Design Application No 001130082**

Brinsea Products Ltd, Station Road, Sandford, N. Somerset, BS25 5RA  
 Tel: 0845 226 0120 Fax: (01934) 820250  
 e-mail: [sales@brinsea.co.uk](mailto:sales@brinsea.co.uk), website: [www.Brinsea.co.uk](http://www.Brinsea.co.uk)